

GENERAL SPECIFICATIONS

NO. REQ'D:
 MODEL: 15 R-L
 MATERIAL: 304 STAINLESS STEEL 2-B FINISH
 GAUGE OR THICKNESS OF MATERIAL
 14 ga. THROUGHOUT
 BUILT IN ACCORDANCE WITH U.L. 1D42
 APPROX. WEIGHT: 100 lbs.
 STATIC WATER CAPACITY: 9.2
 GREASE HOLDING CAPACITY: 49.92 lbs.
 RETENTION TIME: 36.8 SEC.

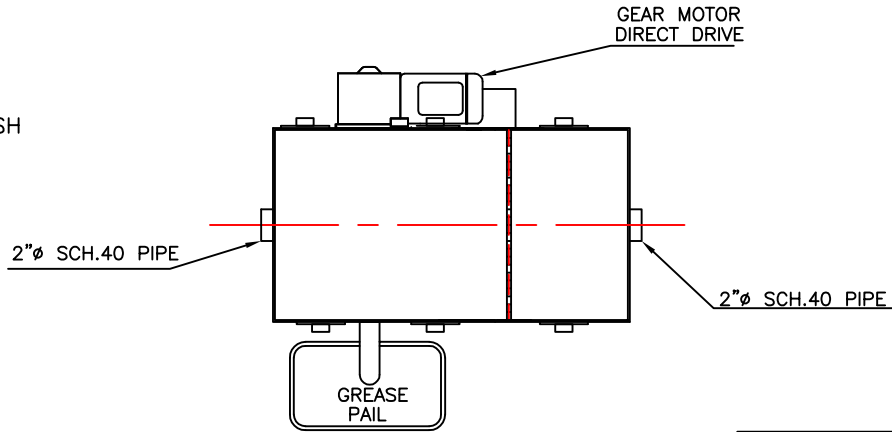

ELECTRICAL INFORMATION

UNIT MUST BE PLUGGED INTO
 A GFI(GROUND FAULT INTERRUPT)RECEPTACLE.

GEARMOTOR- .93 FLA. 115V, 60hz
 ELECTRIC HEATING ELEMENT- 115 V, 1500 W

NOTE:
 THE GREASE STOPPER IS NOT A TRAP FOR SEWER GAS WE
 SUGGEST A TRAP DOWN STREAM FROM THE GREASE STOPPER.

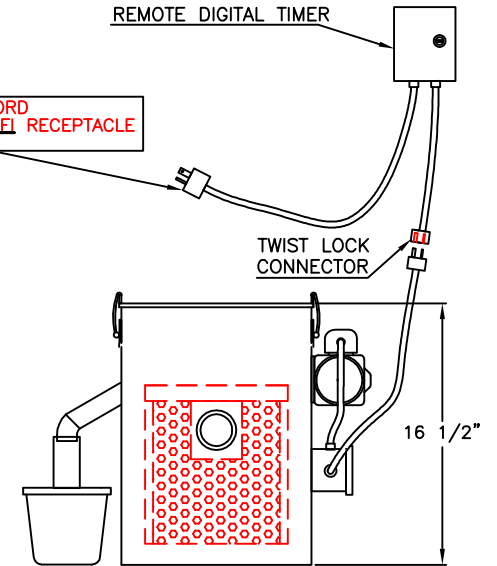
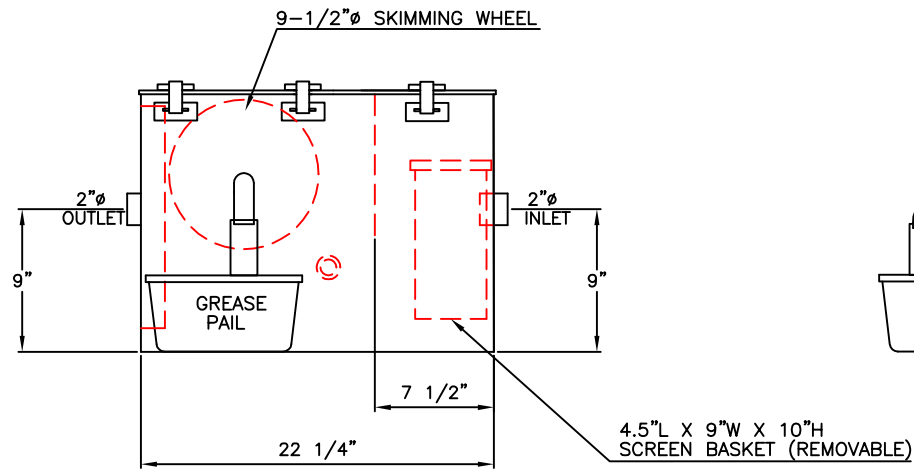
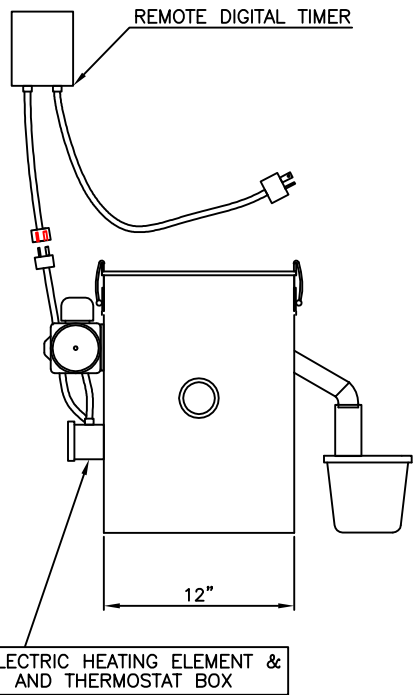

RIGHT TO LEFT FLOW

REVISIONS				
		<h1>Highland Tank</h1>		
GREASE STOPPER MODEL 15 RIGHT - LEFT				
CUSTOMER:				
PROJECT:				
QUOTE NO:				
SCALE:	DATE:	DWG. BY:	CHK'D BY:	DWG. NO.:
1-1/2"-1-1/4"	11/20/06	CLD		GS15R-L